



Solids Flow Detect Model FD-2000



BinMaster: Division of Garner Industries
7201 N. 98th St., Lincoln, NE 68507
402-434-9102 • email: info@binmaster.com
www.binmaster.com

**OPERATING INSTRUCTIONS
PLEASE READ CAREFULLY**

TABLE OF CONTENTS

SAFETY SUMMARY	3
SPECIFICATIONS.....	4
1.0 INTRODUCTION/DESCRIPTION.....	5
2.0 LOCATION AND MOUNTING	5
3.0 CONNECTIONS AND WIRING	8
5.0 CONTROLS AND INDICATORS	10
6.0 CALIBRATION PROCEDURE.....	12

SAFETY SUMMARY

Review the following safety precautions to avoid injury, prevent damage to the equipment and maintain protection methods for hazardous locations.

The product should be installed, commissioned, and maintained by qualified and authorized personnel only. Install according to installation instructions and comply with all national and local electrical codes.

If this product is used in a manner not specified by the manufacturer, the safety and hazardous location protection could be compromised.

Use electrical wire that is sized and rated for the maximum voltage and current of the device and load being supplied.

An external overcurrent protection device or switch must be included in the installation and rated for the voltage and current of the device and load. It should be installed near the equipment and identified as for that equipment. Do not install this product in a manner which makes it difficult to operate the disconnecting device.

Properly ground the enclosure to an adequate earth ground. Observe all switch contact ratings as called out on the nameplate and in the operating instructions. Insure that the enclosure cover is in place and secured tightly after installation.

The product should be installed in such a way as to decrease the risk from electrostatic discharge due to contact or brush discharges. The surface of the equipment should be cleaned only with a wet cloth to reduce the risk of electrostatic discharge.

Before servicing, disconnect power from all circuits entering enclosure before removing cover. After any inspection or servicing, insure the enclosure cover is in place and tightly secured.

In potentially wet environments thoroughly seal all conduit entries.

Safety Terms and Symbols



WARNING: Warning statements identify conditions or practices that could result in injury or loss of life and the ***operating instructions must be consulted.***
Risk of electrical shock.



CAUTION: Caution statements identify conditions or practices that could result in damage to this product or other property.

Safety Precaution



CAUTION: Before removing the enclosure cover, disconnect power from all circuits entering enclosure. Be aware that there may be more than one live circuit.

SPECIFICATIONS

Power Requirements:	2.0 Watts at 24 VDC +/-10%
 External overcurrent protection	2A Max.
Operating Temperature:	-22°F to +140°F (-30°C to +60°C)
Storage Temperature:	-40°F to +176°F (-40°C to +80°C)
Enclosure:	NEMA 4X. IP 66 Die Cast Aluminum, USDA approved powder coat finish
Mounting:	1-1/4" NPT
Conduit Entry:	3/4" NPT
Pressure:	5 PSI above ambient
Altitude:	Up to 2,000m
Process Pressure	80 PSI
Detection Range:	1.5 m (4.9 ft)
Output Delay Range:	Switchable: 0.1 to 3.1 sec / 2.3 to 15.1 sec
Relay Outputs:	250 VAC / 220 VDC / 2A
4-20mA Output:	No Flow: 4 mA +/-4% Flow: 20 mA +/-4% Fault: 22 mA +/-4%
4-20mA Load:	650 Ohms Maximum
Emissions:	24.11 GHz, 6.6 mW typical/9.9 mW maximum
Approvals:	Class II Div 1 Groups E, F, & G; T5

INTRODUCTION/DESCRIPTION

The model FD-2000 solids flow detector is an industrial instrument that senses flow or no-flow conditions of solids and powders in pneumatic pipelines, gravity chutes and feeders. It uses microwave Doppler technology to provide highly sensitive motion detection. The sensor is completely non-intrusive, avoiding contact with the flow stream and associated wear problems.

The FD-2000 is a single piece system that contains the sensing element, the power and output connections and user adjustment controls. It provides both a relay output and current output for indication of flow or no-flow. Both normally closed and normally open contacts are available at the relay output.

The FD-2000 sensor unit emits a low power microwave signal toward the material being monitored. Part of this signal is reflected off the material back to the transducer of the FD-2000. This reflected signal combines with the emitted signal to produce a beat frequency, which is the difference in frequency between the two signals. If the material being monitored is not moving, the reflected signal will be the same frequency as the emitted signal and there will be no beat frequency produced. However, if the material is moving, the reflected signal will be shifted in frequency and a difference or beat frequency will be produced. This shift in frequency is called the Doppler Effect. The presence or absence of this beat frequency is sensed by the FD-2000 to detect a flow or no flow condition.

Microwaves are extremely high frequency radio waves and as such pass through non-metallic materials with negligible attenuation. This means that the FD-2000 can see through a plastic pipe, a glass process seal or the wall of a wooden chute to detect the motion of material inside. This also means that the FD-2000 can look all the way through a plastic pipe or wooden chute and see a person walking on the opposite side. Therefore, in some installations where this situation may occur, a metallic material will need to be placed on the opposite side of the pipe or chute to prevent the FD-2000 from seeing objects on the other side. Adjusting the sensitivity of the FD-2000 to a lower setting may eliminate the sensing of moving objects on the other side of a nonmetallic pipe or chute.

Location and Mounting

The FD-2000 is mounted at the process site where the movement of material is to be monitored. Often this will be on the side of a chute or flow pipe where access by personnel is difficult or limited. When selecting a location, attention should be given to the temperature limits of the sensor to make sure they are not exceeded. And, although the unit is equipped with a filter to reduce the effects of mounting vibrations, it should be mounted where it will not experience excessive vibration as this can be detected as motion and give a false indication of flow.

The sensor best detects movement of material moving directly toward or away from the unit. However, mounting the unit perpendicular to flow usually works because there is adequate fluctuation of material as it flows past to allow detection. In some cases where the material is very light and difficult to detect, it may be necessary to mount the unit at some angle off perpendicular to the flow. An angle of 20 to 30 degrees from perpendicular is usually sufficient. Refer to Figure 1 for examples.

Good Mounting Practice

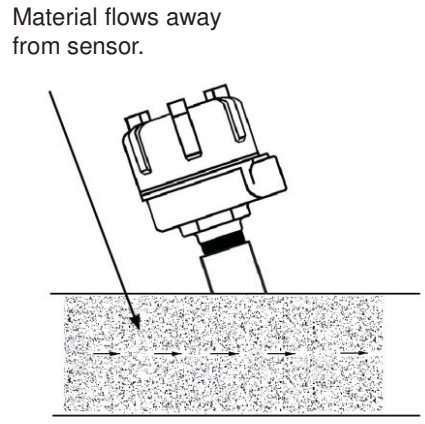
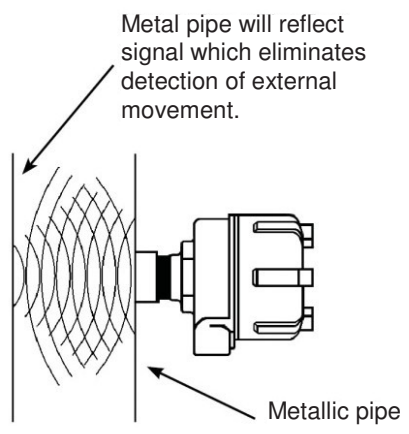
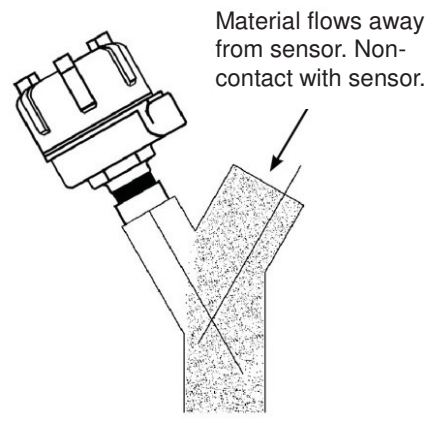
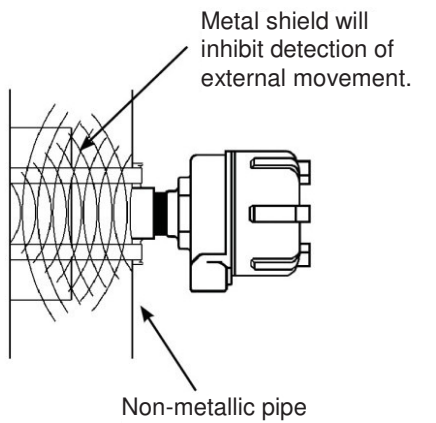

Poor Mounting Practice

Non-metallic pipe without a metal shield permits detection of external movement.

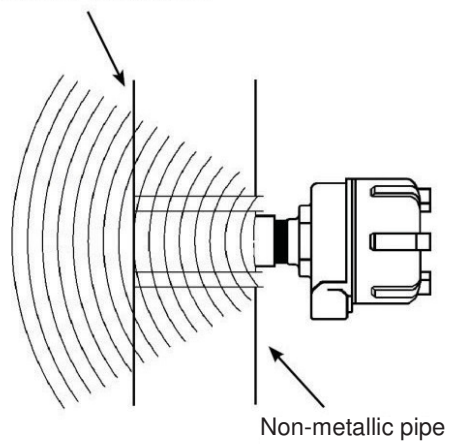

Avoid flow towards the sensor mount.

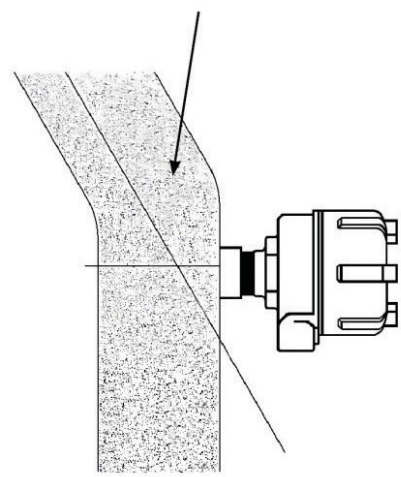

Figure 1

For installations where the sensor needs to monitor flow through a metal pipe or chute, an opening will have to be made in the metal wall. If necessary, a suitable seal made of nonmetallic material should be provided for this opening. For some installations, the seal provided on the FD-2000 sensor would be adequate. Care must be taken so as not to exceed the pressure or temperature rating of the FD-2000.

The unit should be mounted so that the conduit openings are down, as shown in Figure 2. If being used in an environment with high levels of moisture or moist air, then the conduit openings should be sealed with a duct seal compound or appropriate putty.

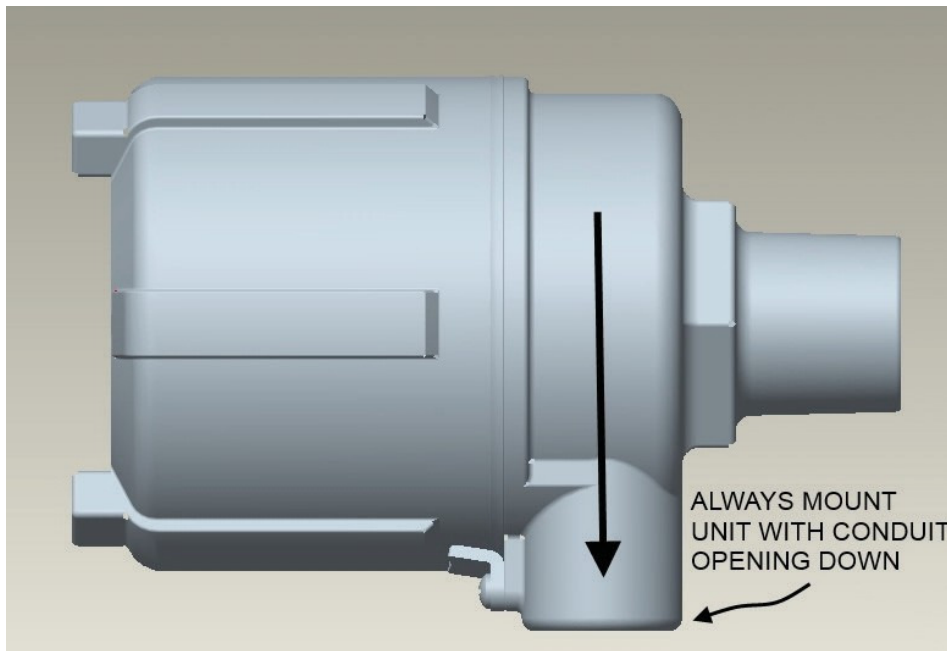



Figure 2

⚠ To summarize, the FD-2000 sensor should be installed such that:

- Its temperature rating is not exceeded
- Its pressure rating is not exceeded
- It does not experience excessive vibration
- An opening is provided in metallic shoots or pipes
- If necessary, mounted off perpendicular to material flow
- Always mount conduit openings down and, if necessary, use duct seal

Connections and Wiring

 Field wiring should conform to all national and local electrical codes and any other agency or authority having jurisdiction over the installation. Use wire that is sized and rated for the maximum voltage and current as per this device and load, and has a temperature rating of at least 90°C. Installation shall be done by qualified personnel.

Terminals are available for the following connections:

- 24 VDC
- 4-20 mA
- OUT
- FAULT

These terminals are accessible by unscrewing the enclosure cover. All wiring should be fed from the outside, through the conduit openings. Terminal labels are printed directly above the terminals on the control plate as seen in Figure 3.

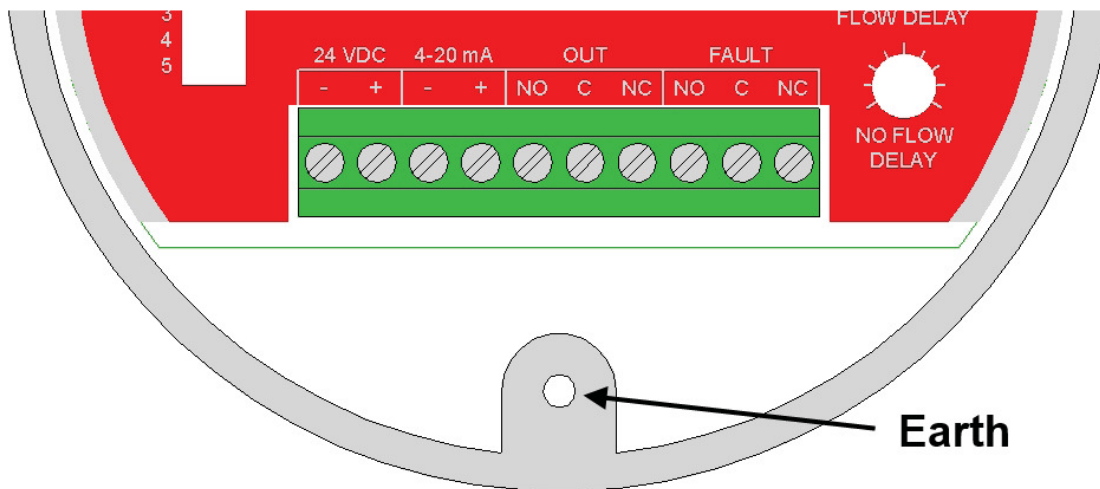

Figure 3

24 VDC

The FD-2000 requires about 2.0 watts of power from a 24 VDC +/-10% source. Refer to Figure 3 for location of these two terminals. Connect the negative of the 24 VDC power source to the far left terminal labeled with the minus sign. Connect the positive to the terminal labeled with the plus sign. A good earth should also be connected at the screw terminal on the inside of the enclosure.

4-20 mA

This is a powered or active current output and can drive up to 650 ohms. Refer to Figure 3 for location of these two terminals. Connect the negative wire coming from the current receiver to the terminal labeled with the minus sign. Connect the positive wire coming from the current receiver to the terminal labeled with the plus sign.

OUT and FAULT

Each of the OUT and FAULT terminals offer an SPDT relay which provides dry contacts for operation of external controls or equipment. Terminal connections are available for the common (C), the normally open (NO) and the normally closed contacts (NC). Refer to Figure 3 for location of these terminals. The relay contacts are rated for 2A at up to 250 VAC or 220 VDC.

Relay Contacts with DIP Switch 1 in the OFF Position

MATERIAL FLOWING

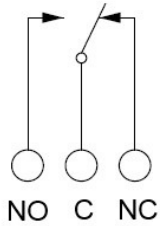

MATERIAL NOT FLOWING

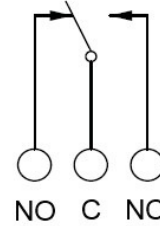

Relay Contacts with DIP Switch 1 in the ON Position

MATERIAL FLOWING

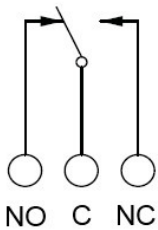

MATERIAL NOT FLOWING

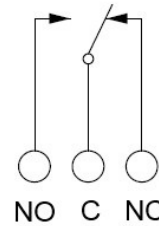

Figure 4

Controls and Indicators

All user controls and indicators are visible by removing the enclosure cover. Refer to Figure 5 for location of the controls and indicators.

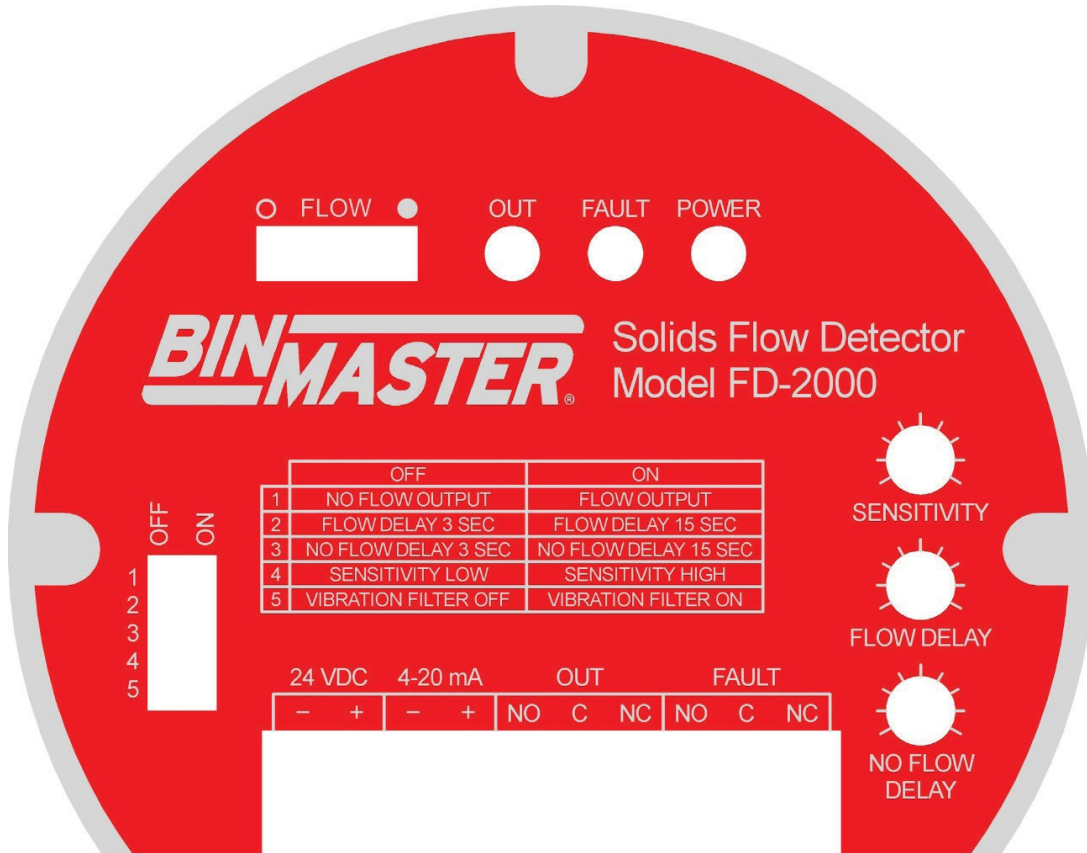

Figure 5

Following is a list of controls and indicators available:

FLOW Indicator – This is to assist in adjusting the sensitivity by indicating the margin between the no-flow and flow conditions. It consists of five multi-colored LEDs, with a red one in the center representing the trip point between flow and no-flow. Indication to the left is no-flow and to the right is flow.

OUT Indicator – This is a yellow LED and will indicate the Flow or No Flow output condition, which corresponds directly with the OUT relay and 4-20mA output current. When the OUT indicator is off, the OUT relay is de-energized and the current output is at 4mA. When the OUT indicator is on, the OUT relay is energized and the current output is at 20mA.

FAULT Indicator – This is a red LED and will indicate if the OUT condition is not guaranteed to be valid; such as when the unit is operating near or outside its rated temperature range or when the internal Doppler sensing element is faulty. This indicator corresponds directly with

the FAULT relay. When the FAULT indicator is off, the FAULT relay is de-energized. When the FAULT indicator is on, the FAULT relay is energized. Also, the 4-20mA current output will be at 22mA when in the FAULT condition.

POWER Indicator – This is a green LED and simply indicates when power is applied to the unit.

SENSITIVITY Control – This is used to adjust the sensitivity or detection range of the unit.

FLOW DELAY Control – This is used to adjust the delay from when material has started to flow to when the OUT relay and indicator are switched.

NO FLOW DELAY Control – This is used to adjust the delay from when material has stopped flowing to when the OUT relay and indicator are switched.

DIP Switches

Switch 1 (NO FLOW OUTPUT / FLOW OUTPUT) – For selecting between a no-flow or flow output condition. The OUT relay will be energized and the OUT indicator will be on based on this selection. Slide the switch to the off position for a no flow output. Slide the switch to the on position for a flow output.

Switch 2 (FLOW DELAY 3 SEC / FLOW DELAY 15 SEC) – For selecting the desired flow delay range. Slide the switch to the off position for an on delay range of 0.1 to 3.1 seconds. Slide the switch to the on position for a range of 2.3 to 15.1 seconds.

Switch 3 (NO FLOW DELAY 3 SEC / NO FLOW DELAY 15 SEC) – For selecting the desired no flow delay range. Slide the switch to the off position for an off delay range of 0.1 to 3.1 seconds. Slide the switch to the on position for a range of 2.3 to 15.1 seconds.

Switch 4 (SENSITIVITY LOW / SENSITIVITY HIGH) – For selecting the sensitivity or detection range of the unit. Slide this switch to the off position for low sensitivity or when the moving target will be near the unit. Slide this switch to the on position for high sensitivity or when the target will be far from the unit.

Switch 5 (VIBRATION FILTER OFF / VIBRATION FILTER ON) – For enabling or disabling the vibration filter, which will eliminate undesirable signals from vibrating equipment. Slide this switch to the off position to turn the filter off. Slide this switch to the on position to turn the filter on.

Calibration Procedure

With the sensor mounted in position and wired, unscrew the enclosure cover to expose the control plate. Then follow these steps:

1. Start with the DIP switches set as follows:
 - a. Switch 1 on for a FLOW OUTPUT.
 - b. Switch 2 off for FLOW DELAY 3 SEC.
 - c. Switch 3 off for NO FLOW DELAY 3 SEC.
 - d. Switch 4 off for SENSITIVITY LOW.
 - e. Switch 5 off for VIBRATION FILTER OFF.
2. Turn the SENSITIVITY, FLOW DELAY and NO FLOW DELAY controls fully counter clock-wise for their minimum setting.
3. With no material flowing (the OUT indicator should be off), slowly turn the SENSITIVITY control clock-wise until the OUT indicator turns on or until the control is at maximum. Note the actuating point for the no-flow condition.
4. Start material flowing and slowly turn the SENSITIVITY control counter clock-wise until the OUT indicator just turns off. Note the actuating point for the flow condition.
5. Turn the SENSITIVITY control midway between the no-flow and flow actuating points. If vibration is causing unwanted detection or increases the receiving level of the no-flow condition, then set DIP switch 5 to VIBRATION FILTER ON and repeat steps 2 to 5. If the flowing material is not detectable or there is very little margin between the no-flow and flow actuating points, then set DIP switch 4 to SENSITIVITY HIGH and repeat steps 2 to 5.
6. In order to detect irregular flow, set DIP switch 2 and adjust the FLOW DELAY control as needed.
7. In order to not detect irregular flow, set DIP switch 3 and adjust the NO FLOW DELAY control as needed.
8. If the desired output is for indication of no flow, then you can set DIP switch 1 for NO FLOW OUTPUT.

LIMITED WARRANTY

BinMaster warrants this product against defects in material and workmanship for two (2) years according to the following terms;

- 1.) This warranty extends to the original purchaser only and commences on the date of original purchase.
- 2.) BinMaster's sole obligation under said warranty is to repair, or at its option replace the defective parts. The buyer shall have no other remedy. All special, incidental and consequential damages are excluded. The buyer must deliver the product under warranty prepaid to the factory. BinMaster's obligation is limited to the cost of material and labor to repair or replace, and does not include transportation expenses.
- 3.) This warranty shall be voided, in our sole judgment, by alterations of equipment except by BinMaster, or tampering with, improper installation or maintenance, accident or misuse, or act of God. This warranty expressly excludes all damage to the product resulting from careless or neglectful packaging or transportation. The warranty does not extend to repairs made necessary by normal wear.
- 4.) This warranty is in lieu of all other warranties, expressed or implied including any implied warranties or merchantability or fitness for particular purpose. No employee, agent, franchise dealer or other person is authorized to give any warranties of any nature on behalf of BinMaster.
- 5) BinMaster shall in no event be responsible for any warranty work done without first obtaining Bin- Master's written consent.
- 6) Except as provided herein, BinMaster shall have no liability, loss or damage caused or alleged to be caused directly or indirectly by this equipment.
- 7) This warranty gives the buyer specific legal rights, and you may also have other rights which vary from state to state.
- 8) For service, please call 402-434-9102.

Customer Service

BinMaster offers a toll-free Customer Service phone number 1-800-278-4241. You may call the Customer Service Department for technical and application assistance Monday through Friday from 8:00 AM to 5:00 PM Central Time. International customers call us at (402) 434-9102 or reach us via fax at (402) 434-9133.

Disposal

This product consists of materials that can be recycled by specialized recycling companies. It uses recyclable materials are designed to be easily separated. Consult local authorities for proper disposal locations.

Repair

This product contains no user serviceable parts. For repair please consult factory.

Certifications

UL

Conforms to UL STDS 61010-1 and 1203

CAN/CSA

Certified to CAN/CSA STDS C22.2 No. 61010-1 and No. 25



BinMaster Level Controls

A Division of Garner Industries 7201 North 98th Street Lincoln, NE 68507-9741

Phone: 402-434-9102, Fax: 402-434-9133

Solids Flow Detect Model FD-2000