

CENTER[®] 328

MINI SOUND LEVEL METER

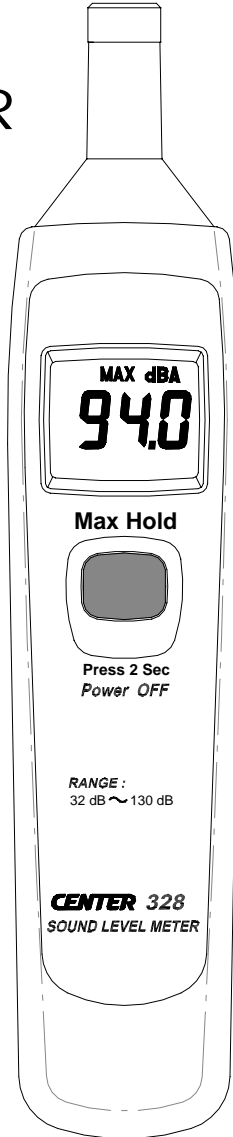

Instruction Manual

CENTER TECHNOLOGY CORP.

CONTENTS

TITLE	PAGE
I. Safety Information.....	1
II. General Description.....	1
III. Features.....	2
IV. Specifications.....	2
V. Name and Functions.....	3
VI. Measurement Preparation.....	5
VII. Operating Precautions.....	5
VIII. Calibration.....	6
IX. Measurement.....	6

I. Safety Information

Read the following safety information carefully before attempting to operate or service the meter.

Use the meter only as specified in this manual; otherwise, the protection provided by the meter may be impaired.

Environment Conditions

Altitude up to 2000 meters

Relative humidity 90% max.

Operation Ambient 0 to 40

Maintenance & Clearing

- 1 Repairs or servicing not covered in this manual should only be performed by qualified personnel.
- 2 Periodically wipe the case with a dry cloth. Do not use abrasives or solvents on this instrument.

Safety symbols

Comply with EMC

When servicing, use only specified replacement parts.

II. General Description

Thank you for using our Sound Level Meter. To ensure that you can get the most from it, we recommend that you read and follow the manual carefully before use.

This unit conforms to the IEC61672-1 Class2, ANSI S1.4 Type2 for Sound Level Meters.

This Sound Level Meter has been designed to meet the measurement requirements of safety Engineers, Health, Industrial safety offices and sound quality control in various environments.

III. Features

- Mini size
- Easy to use
- High performance at a Low cost
- Autoranging
- Maximum recording
- 4-digit LCD with a resolution of 0.1dB
- Internal Calibrator (94dB@1kHz)

IV. Specifications

Standard Applied: IEC61672-1 Class2, ANSI S1.4 Type2.

Frequency Range: 31.5Hz to 8KHz

Measuring Level Range: 32dB to 130dB

Microphone: 1/2 inch electret condenser microphone

Display: LCD

Resolution: 0.1dB

Display Update: 0.5 sec.

Frequency Weighting: A

Time Weighting: FAST

Accuracy:

±1.4dB (under reference conditions, 94dB@1kHz)

Alarm Function: **“OVER”** when input is more than upper limit of range.

“UNDER” when input is Less than lower limit of range.

Power Supply:

Two IEC R03 (size “AAA”) batteries, 1.5V X 2.

Battery Life: Approx. 50 hours (Alkaline Batteries LR03)

Operation Temperature: 0 to 40 (32 to 104)

Operation Humidity: 10 to 90%RH

Storage Temperature: -10 to 60 (14 to 140)

Storage Humidity: 10 to 75%RH

Dimensions: 206 mm x 42 mm x 25 mm

8.1"(L) x 1.7" (W) x 1.0" (H)

Weight: 100g (0.22 lbs) (including batteries)

Accessories: two 1.5V batteries, instruction manual, screwdriver, windscreen.

V. Name And Functions

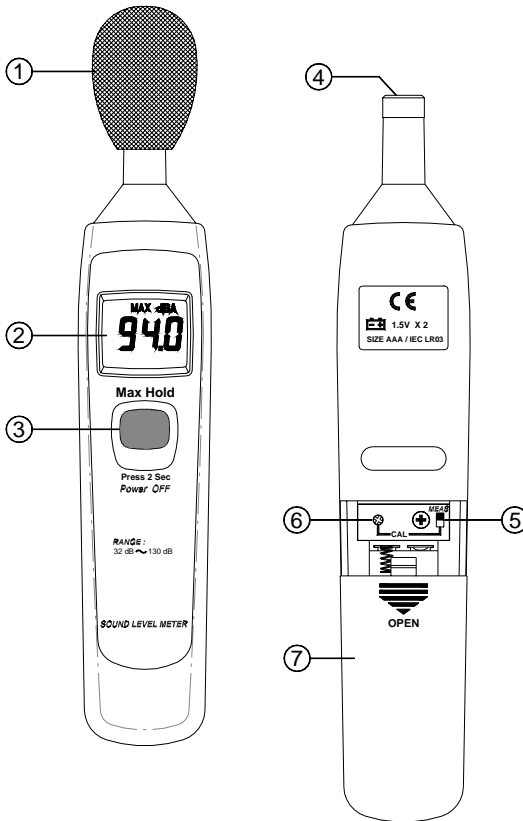

1 Windscreen

When making outdoor measurements in windy weather, wind noise at the microphone can cause measurement errors. Such effects can be using the windscreen.

2 Display screen

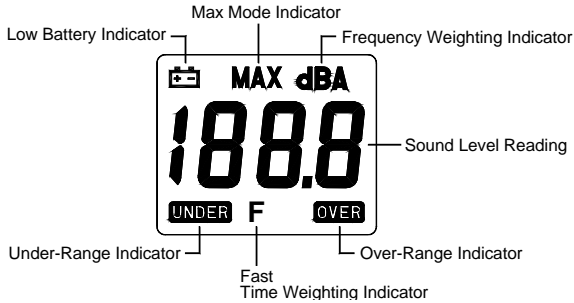

3 Power On/Off & Max Hold button

Power-on

Turn the unit on by press the “Max Hold” button.

Max recording mode

Press the “Max Hold” button to enter the Max Hold mode under the power-on. The LCD will show “MAX” symbol. The MAX recording mode captures and stores the maximum input values detected. When the unit detects an input that is above the recorded maximum, the unit records the new maximum value.

Press the “Max Hold” button again to exit the MAX mode .Recorded values are erased, “MAX” symbol disappears.

Power-off

Turn the unit off by holding down the “Max Hold” button for at least 2 seconds .The LCD will show “OFF”, release the button.

4 Microphone

1/2 inch electret Condenser microphone

5 MEAS / CAL

Measurements or internal calibrator select switch

6 Calibration adjustment**7 Battery Cover**

VI. Measurement Preparation

(1) Inserting the batteries

Lightly press the battery cover and slide it to the down. Insert two 1.5V batteries, paying attention to the polarity as indicated in the compartment. Replace the cover.

(2) Battery Replacement

When the battery voltage drops below the operating voltage, this  symbol will appear. Replace 1.5 Volt batteries.

VII. Operating Precautions

- (1) Wind blowing across the microphone will bring additional extraneous noise.

When using the instrument in the presence of wind, it is a must to mount the windscreen to not pick up undesired signals.

- (2) Calibrate the instrument before operation if the instrument was not in use for a long time or operated in bad environment.
- (3) Do not store or operate the instrument at high temperature and high humidity environment.
- (4) Keep microphone dry and avoid severe vibration.

- (5) If the unit is not used for a long period of time, the batteries will have to be removed from the battery compartment, since it might leak.

VIII. Calibration

Before starting a measurement, the unit must be calibrated. There are two types of calibration: internal electrical calibration and acoustic calibration using a sound calibrator. Normally, internal electrical calibration only is required.

Internal Calibrator(94dB@1kHz)

Lightly press the battery cover and slide it to the down. Slide the switch to the down. Verify that the Cal Mode is set to "Internal" CAL. LCD shows "CAL" approx. 1 sec. Activates the built-in oscillator(1 kHz, sine wave) for electrical calibration of the unit . When calibration is end, slide the switch to the up "MEAS" position

IX. Measurement

- (1) Turn power ON to measure noise sound.
For general sound level measurements, A - frequency weighting and F(FAST) time weighting(dynamic characteristics) the setting should be used.
- (2) Make sure that slide the switch to the "MEAS" position on rear of the unit.
- (3) Hold the instrument comfortably in hand and point the microphone at the suspected noise source.
- (4) The numeric level indication shows the currently measured sound level .The reading is updated twice every second.

CENTER[®] CENTER TECHNOLOGY CORP.

4 / F NO. 415, Jung-Jeng Rd., 238 Shu-Lin, Taipei, Taiwan

E-Mail : center@centertek.com

http : // www.centertek.com

328-00



Distributor in Australia

Pacific Sensor Technologies Pty Ltd

Unit 4, 3 Neutron Place Rowville, VIC 3178 Australia

1300 662 720 | sales@pacificsensortech.com.au

www.pacificsensortech.com.au