

CENTER 352 INFRARED THERMOMETER INSTRUCTION MANUAL

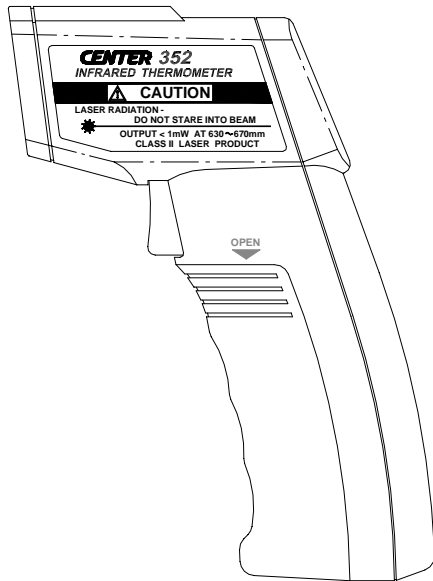

Warning of laser

Do not point laser beam to human eyes directly or indirectly from reflective surfaces.

Cautions

Before using the infrared thermometer the operator have to notice the following:

- Keep away from electrical welders, induction heaters and other EMF sources.
- When using this thermometer under big or abrupt ambient temperature changes, allow 15 minutes for the unit to stabilize before use.
- Do not keep this thermometer in the environment of high temperature for a long period.
- Keep away from dusty environment and keep it in the carry case after operation to avoid contamination of optical lenses.

LCD Display

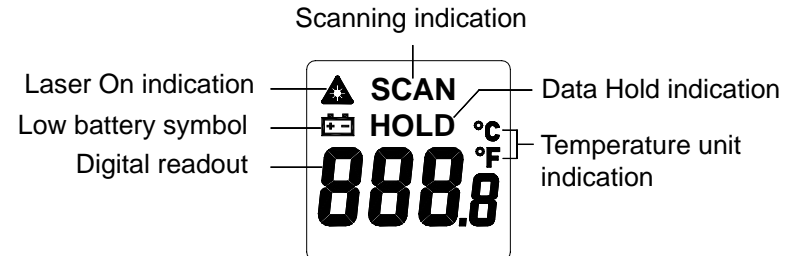

Switch and Functions

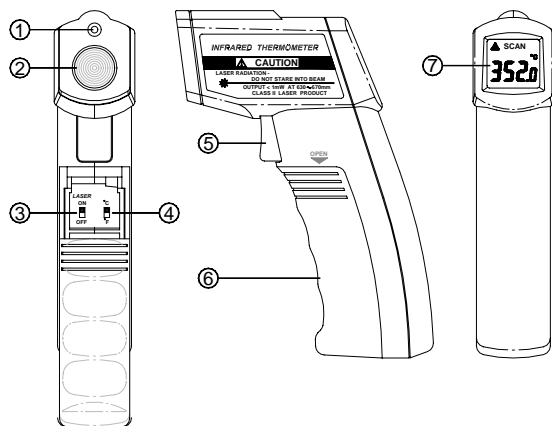

- ① Laser emitting hole
- ② Infrared sensor aperture
- ③ Laser on/off switch
- ④ °C/°F switch
- ⑤ Measuring Trigger

When measuring a temperature, point the unit to the object and pull the trigger. Be sure to consider distance-to-spot size ratio and field of view. The laser is used for aiming the target for reference only. The temperature reading will be updated on the LCD. When the operator releases the trigger, the reading will be automatically held on the LCD for 10 more seconds. After 10 seconds this thermometer will power down itself to save battery.

- ⑥ Battery cover
- ⑦ LCD display

Changing Battery

When the battery voltage drops below the required range for reliable operation, the low battery symbol  will appear, indicating it is time to replace the battery.

To change the 9V battery, detach the battery compartment cover by pushing the engraved pattern on the handle and pull down. Change the 9V battery with new one and put the battery cover back.

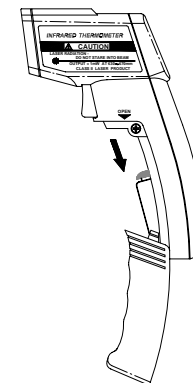

Distance to Spot Ratio (D/S)

You have to make sure that the detection area you want to measure is larger than the required spot size to get a correct reading. The temperature you get is an average temperature of the detected region. The smaller the target, the shorter distance is required for the measuring. (Please refer to the diagram on the side of the unit)

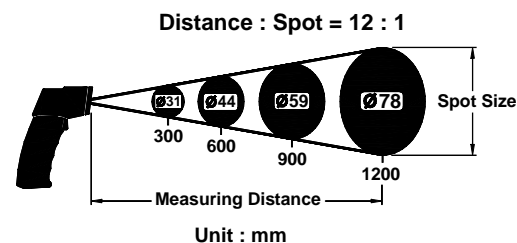

Emissivity

Emissivity is a term used to describe the energy-emitting characteristics of materials. The higher of this value means the more radiation emittance the materials has. Most organic materials and painted or oxidized surfaces have an emissivity of 0.98. Metal surfaces or shiny materials has a lower emissivity and give inaccurate readings by this tester. Please note this during applications.

Maintenance

Blow off loose particles using a lens blow. Gently brush remaining debris away with a lens brush. Carefully wipe the surface with a moist cotton swab. The swab may be moistened with water.

NOTE: DO NOT use solvents to clean the glass lens.

GENERAL SPECIFICATIONS

Field of View	12:1
Detector	Thermopile
Temperature Range	-20~500°C -4~932°F
Resolution	0.1°C, 0.2°F
Operation Temperature & Humidity	0~40°C, 32~104°F, 10~90%RH
Storage Temperature & Humidity	-10~60°C, 14~140°F, ≤ 75%RH
Accuracy	±2°C(4°F) or ±2% of reading
Repeatability	Within ±1% of reading or ±1°C(2°F)
Response Time	0.5 second
Display	4 digit LCD
Display Illumination	Backlight by LED
Target Indicator	Laser spot
Emissivity	0.98
Power Off	Automatic power-off after 10 seconds
Low Battery	Indicated by “  ”
Battery	9V battery, 006P, IEC6F22, NEDA1604
Power Life (Alkaline)	Approximately:15 hrs
Accessories	9V battery, instruction manual, carrying case
Dimensions	157.5x115x36mm, 17.5x4.5x1.4inch
Weight	Approx.180g

CE Certification

This instrument conforms to the following standards:

- EN50081-1:1992 Electromagnetic Emissions
- EN50082-1:1997 Electromagnetic Susceptibility

Tests were conducted using a frequency range of 80-1000 MHz with the instrument in three orientations. The average error for the three orientations is $\pm 1.5^{\circ}\text{C}$ ($\pm 3.0^{\circ}\text{F}$) at 3V/m throughout the spectrum. However, between 162 MHz and 792 MHz at 3V/m, the instrument may not meet its stated accuracy.