

PRODUCT DESCRIPTION

The P0212 transmitter with 0-10 V output is designed for temperature measurement in air condition ducts. In combination with a thermowell is the transmitter suitable for temperature measurement of liquids in tubing.

The device settings can be changed with using the PC connected via the optional SP003 communication cable (not included in delivery). The **TSensor** software (free to download from www.cometsystem.com) provides to change output temperature range, temperature unit choice (°C or °F), output voltage range and perform the adjustment.

<u>Setting from the manufacturer</u>	voltage output range:	0 to 10 V
	temperature range:	-30 to +80 °C
	temperature unit:	°C

DEVICE INSTALATION

The devices are designed for mounting in an air condition ducts or pipelines (the mounting parts are not included in delivery).

The connecting terminals are accessible after unscrewing the four screws in the corners of the case and removing the lid. Pass the connecting cable through released gland and connect the wires to terminals (for device connection it is recommended to use a shielded cable with maximum length of 15 m and with external diameter of 4 to 8 mm). Finally tighten the glands and screw the lid (check the integrity of the seal).

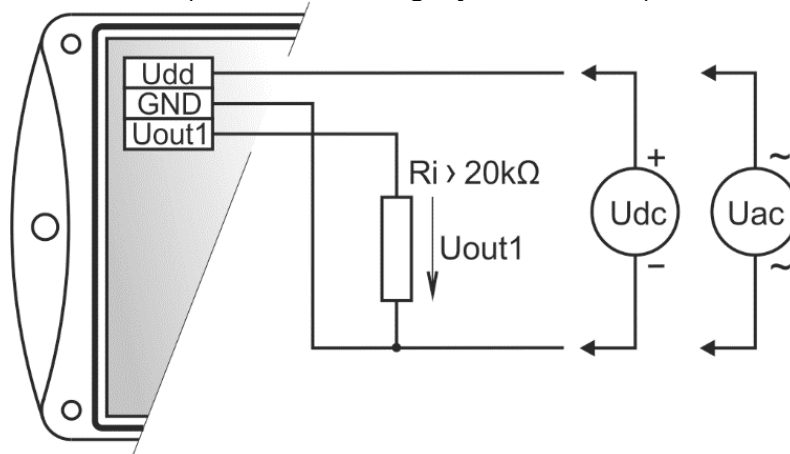

Devices don't require special operation and maintenance. It is recommended to verify the accuracy of measurement.

WARNING

- The devices are not designed for locations with chemically aggressive environment.
 - Don't connect transmitter while power supply voltage is on.
 - The cables should be located as far as possible from potential interference sources.
 - Installation, commissioning and maintenance may only be carried out by personnel with qualification by applicable regulations and standards.
-

PROCEDURE OF MODIFICATION OF DEVICE ADJUSTMENT

- install **TSensor** configuration program on the PC (take care about installation of drivers for USB communication cable)
- connect SP003 communication cable to USB port of the PC (installed USB driver detect connected cable and create virtual COM port)
- unscrew four screws and remove the lid (if device is already installed to measuring system, disconnect wires from terminals)
- connect SP003 communication cable to the device (see picture)
- run installed **TSensor** program and continue in accordance with its instructions
- when new setting is saved and finished, disconnect the cable from the device, connect wires into its terminals and place the lid back to the device

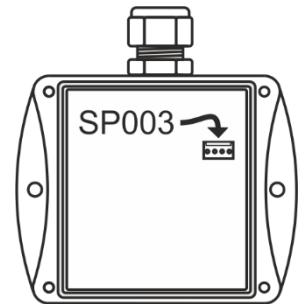

ERROR STATES OF THE DEVICE

The error status of the device is indicated by the value of the output voltage. The voltage value less than -0.1 V indicates low resistance of temperature sensor (short circuit) or serious error (contact distributor of the device). The voltage value about 10.5 V indicates high non-measurable resistance of temperature sensor (opened circuit).

DIMENSIONS

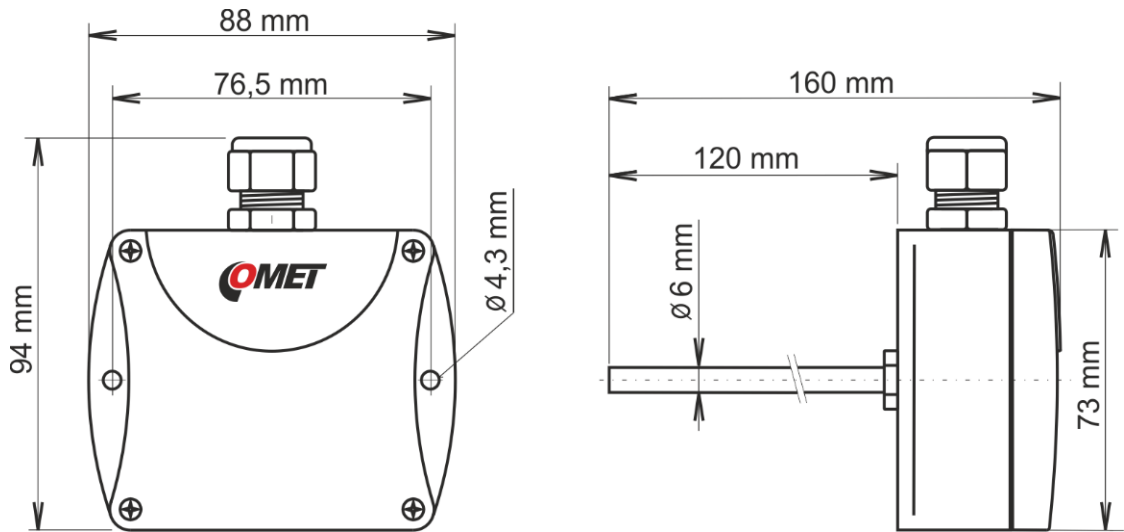

MEASURED VALUE

Temperature:

Measuring range:

-30 to +150 °C

Accuracy:

± 0.4 °C for temperature up to 100 °C

± 0.4 % from measured value over 100 °C

Response time:

t63 < 45 s

*temperature step (0..100) °C, stem with thermowell
immersed to fluid, flow velocity 1 m/s*

GENERAL

Power supply voltage:

- 15 to 30 Vdc
- 24 Vac

Voltage output range:

0 to 10 V

Output load capability:

min. 20 kΩ

Recommended interval
of calibration:

2 years

Protection:

IP65

Working position:	arbitrary
Storage temperature range:	-30 to +80 °C
Storage humidity range:	0 to 100 %RH (no condensation)
Electromagnetic compability:	EN 61326-1
Weight:	approximately 140 g
Housing material:	ASA

OPERATING CONDITIONS

Temperature range of housing with electronics:	-30 to +80 °C
Temperature range of measuring end of stem:	-30 to +150 °C
Relative humidity range (no condensation):	0 to 100 %RH

END OF OPERATION

Dispose of the device according to statutory regulations.

TECHNICAL SUPPORT AND SERVICE

Technical support and service is provided by distributor. For contact see warranty certificate. You can use discussion form at web address www.forum.cometsystem.cz

© Copyright: COMET SYSTEM, s.r.o.

It is prohibited to copy and make any changes in this manual, without explicit agreement of company COMET SYSTEM, Ltd. All rights reserved.

COMET SYSTEM, Ltd. makes constant development and improvement of their products. Manufacturer reserves the right to make technical changes to the device without previous notice. Misprints reserved.