

## PRODUCT DESCRIPTION

**Programmable monitoring systems** for 19" rack mounting with Ethernet connection are designed to measure temperature, relative humidity and barometric pressure of air in non-aggressive environment, to signal alarms and to control external devices. Three galvanically not isolated binary inputs are intended for detection of binary signals.

**The function of the two output relays** can be set from the device web pages. The device allows two alarm limits to be set for each measured value. In response to the change of the alarm state a relay may be closed, an acoustic signal may be activated or an alarm message may be sent by email or other communication protocol. The status of the output relays can be controlled remotely via Ethernet, too. Following computed values are supported - dew-point temperature, absolute humidity, specific humidity, mixing ratio, specific enthalpy and humidex. The currently measured values are shown on a two-line LCD display.

**Formats of Ethernet communication** that are supported: HTTP – web, Modbus TCP protocol, SNMPv1, XML and SOAP protocol. Alarm messages are sent via email, SNMPv1 Trap or Syslog. To set all devices including their alarm limits embedded websites can be used. A device connected to a local network can be found by the *TSensor* software (free to download at [www.cometsystem.com](http://www.cometsystem.com)).

Type *	Measured values	Construction	Mounting
H3531R	T + RH + CV	probe on a cable	rack 19"
H4531R	T	external probe Pt1000/3850 ppm	rack 19"
H7531R	T + RH + P + CV	probe on a cable	rack 19"

\* Models marked HxxxxZ are custom - specified devices

T...temperature, RH...relative humidity, P...barometric pressure, CV...computed values

## INSTALLATION, OPERATION AND CONFIGURATION

Monitoring systems are intended for mounting in 19" rack (mounting screws and self-retaining nuts are included). For binary sensors and external probe connection choose shielded cables (external diameter 4 to 6.5mm) with a wire cross-section of 0.14 to 1.5 mm<sup>2</sup>. Maximum binary sensor and external probe cable length is 10 m. The binary sensor and external probe cable shielding is connected to a proper terminal device only, do not connect it to other circuitry and do not ground it. All cables should be located as separately as possible from potential interference sources. Pay attention to device mounting, because incorrect choice of working position or measuring point could adversely affect the accuracy and long-term stability of measured values.

To connect the device to the network it is necessary to know a new suitable IP address. Please contact the network administrator to obtain the IP address. The device can obtain an IP address automatically from the DHCP server, or a static IP address can be set manually. The default IP address of each device is preset to **192.168.1.213**. After connecting the external probe, the Ethernet cable and the power adapter, the device IP address needs to be changed in the web pages. To change the IP address, the *TSensor* software can be used alternatively.

Monitoring systems do not require special maintenance. We recommend verifying the measurement accuracy regularly by calibration.

## MONITORING AND VALUES RECORDING

For data monitoring and auditing it is recommended to use the Comet Database software. A trial version of Comet Database is available at [www.cometsystem.com](http://www.cometsystem.com). For monitoring, software and SCADA systems from third party vendors can be used. For data acquisition a communication protocol can be used which is supported by the device.

## ERROR STATES

The device continuously checks its state during operation. If an error appears, the relevant code is displayed: **Err 1** – the measured or calculated value is above the upper limit, **Err 2** – the measured or calculated value is below the lower limit or a pressure measurement error has occurred, **Err 0**, **Err 3** and **Err 4** – a serious error has occurred, please contact the distributor of the device.

## SAFETY INSTRUCTIONS



- Humidity and temperature sensors of the device should not be operated and stored without a filter cap.
- Temperature and humidity sensors should not be exposed to direct contact with water and other liquids.
- It is not recommended to use the humidity monitoring systems for long time under condensation conditions.
- Take care when unscrewing the filter cap as the sensor element could be damaged.
- Use only a power adapter which is approved according to technical specifications and relevant standards.
- Don't connect or disconnect devices while power supply voltage is on.
- Installation, electrical connection and commissioning should be performed by qualified personnel only.
- The devices contain electronic components. Dispose of them in accordance with legal requirements.
- **To supplement the information in this data sheet** read the manuals and other documentation, which are available in the Download section for a particular device at [www.cometsystem.com](http://www.cometsystem.com).

# Technical specifications

Device type	H3531R	H4531R	H7531R
Supply voltage / power consumption	12 Vdc / 1W	12 Vdc / 1W	12 Vdc / 1W
Powering of external sensors and detectors	+12 Vdc / max. 400mA, +5 Vdc / max. 500mA, total power consumption max. 5W		
Relay outputs	max. switching voltage ... 50V, max. switching current ... 2A, max. switching power ... 60 VA		
Binary inputs	low level input voltage ... 0 to 0.5V, high level input voltage ... 3 to 30V, current through closed contact ... 25µA		
Temperature measuring range	-30 to 105 °C	-200 to 600 °C	-30 to 105 °C
Accuracy of temperature measurement	± 0.4°C	± 0.2°C (without probe)	± 0.4°C
Relative humidity (RH) measuring range *	0 to 100 %RH	—	0 to 100 %RH
Accuracy of humidity measurement from 5 to 95 %RH at 23°C	± 2.5 %RH	—	± 2.5 %RH
Barometric pressure measuring range	—	—	600 to 1100 hPa
Accuracy of barometric pressure measurement at 23°C	—	—	± 1.3 hPa
Other calculated humidity variables - dewpoint temperature, absolute humidity, specific humidity, mixing ratio, specific enthalpy, humidex	yes	—	yes
Recommended calibration interval	1 year	2 years	1 year
Protection class of the case with electronics	IP30	IP30	IP30
Protection class of the sensors cover	IP40	—	IP40
Temperature operating range of the case with electronics **	-30 to +80°C	-30 to +80°C	-30 to +80°C
Temperature operating range of the measuring probe	-30 to +105°C	—	-30 to +105°C
Humidity operating range	0 to 100%RH	0 to 100%RH	0 to 100%RH
Mounting position of the humidity and temperature probe	any position ***	—	any position ***
Storage temperature range (0 to 100%RH, no condensation)	-30 to +80°C	-30 to +80°C	-30 to +80°C
Electromagnetic compatibility according to	EN 61326-1	EN 61326-1	EN 61326-1
Weight	1090 (1130, 1210) g	1025 g	1090 (1130, 1210) g
Dimensions [mm]			

## Electrical wiring

### Binary inputs

Configuration is done by DIP switches 1,2,3

open contact ..... DIP - OFF

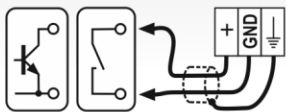

external voltage ..... DIP - ON

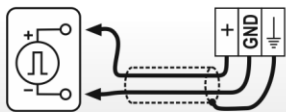

### H3531R, H7531R

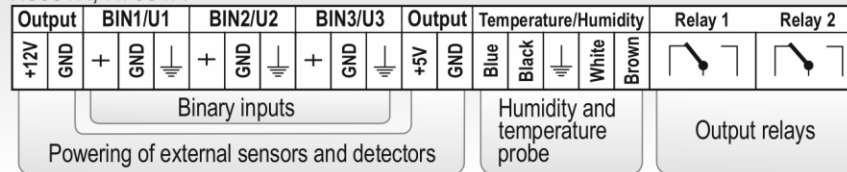

### H4531R

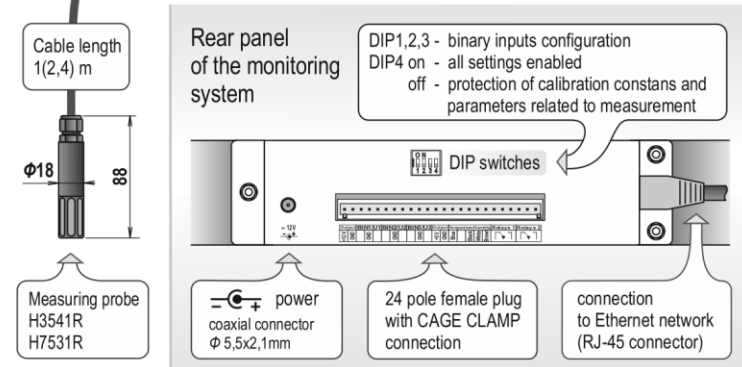
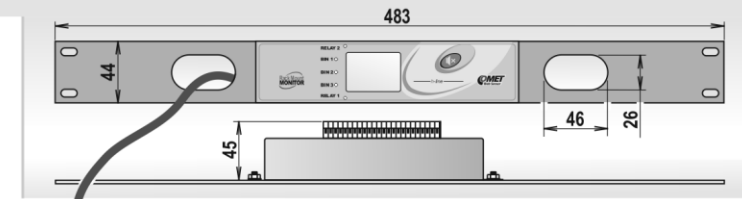
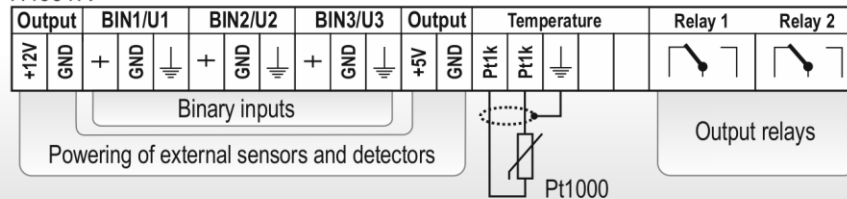

\* The relative humidity measuring range is limited at temperature above 85°C, see manuals for devices  
 \*\* It is recommended to switch off the LCD display at ambient temperature above 70°C.

\*\*\* if it can lead to long term condensation of water, it is necessary to use the probe at position with sensor cover downwards